

SYS-BLD-300B DC Brushless Motor Driver

Overview:

SYS-BLD-300B: Suitable for 48V, 440W Or 24V, 300W three-phase brushless DC motor speed adjustment.

Electrical parameters:

parameter	Min	Typical	Max	Unit
Input voltage	12	48	56	VDC
Output current	-	-	15	A
motor speed	0	-	20000	RPM
Hall signal voltage	-	-	5	V
Hall drive current	12	-	-	mA
External speed potentiometer	-	10	-	KΩ



Environmental indicators:

envirnmental factor	Environmental indicators
cooling method	Natural cooling or forced cooling
Use occasion	Avoid dust, oil and corrosive gases
Operating temperature	10°C-+50°C
environment humidity	90%RH(no condensation)
humidity	5.7m/S2max
storage temperature	0°C-+50°C

Mechanical dimensions and installation drawings:

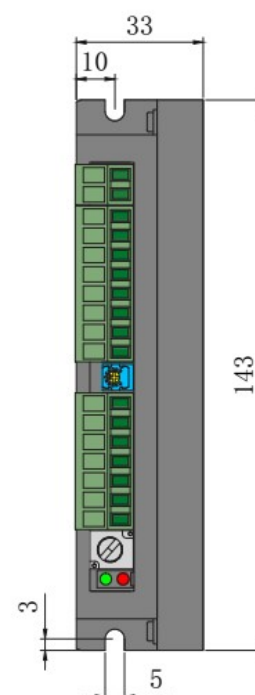
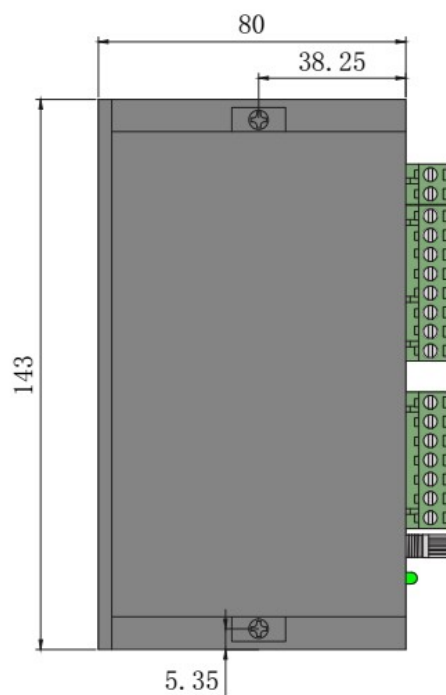

**Driver interface and wiring diagram:
Driver interface**

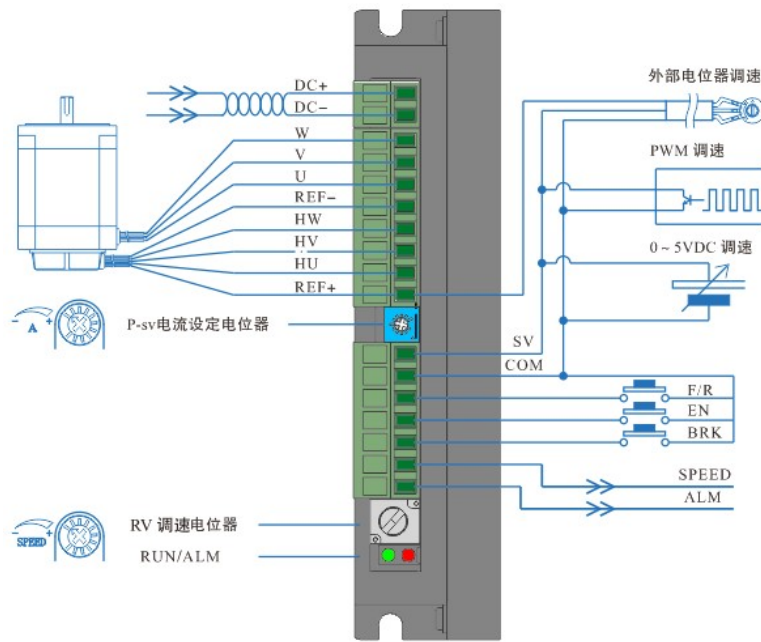

Input connection

signal	Terminals	content
control signal	BRK	Brake signal control terminal, high level or port suspension motor brake stops, low level or BRK and COM short circuit operation
	EN	Stop signal control end, high level or disconnected motor slow stop, low level or EN and COM shorted for normal operation
	F/R	turned off or high level, the motor rotates forward. The F/R and COM are shorted or the low level ,motor is reversed.
	COM	Common port (0V reference level)
	SV	①External speed regulator potentiometer; ②External analog voltage input; ③PWM speed control signal input
Hall signal	REF+	DC Brushless Motor Hall Signal Power Line
	HU	DC Brushless Motor Hall Signal HU
	HV	Brushless DC Hall Signal HV
	HW	DC Brushless Motor Hall Signal HW
	REF-	Brushless DC Motor Hall Signal Grounding
Motor signal	U	DC brushless motor U phase
	V	DC brushless motor V phase
	W	DC brushless motor W phase
Power connection	DC+	DC power input positive (voltage range: DC12-56V)
	DC-	DC power input negative
output signal	SPEED	Corresponding to the operating speed of the motor, the corresponding pulse frequency is output
	ALM	When the motor or drive control, the fault signal output signal is normally 5V, and when the fault occurs, the voltage is 0V

Output signal diagram

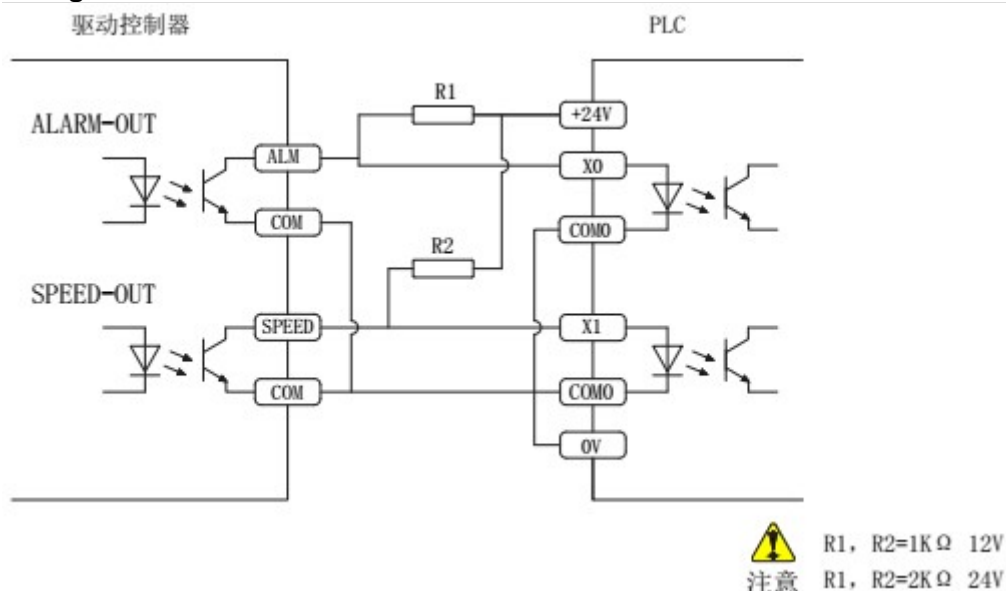

Function selection setting and operation:

Acceleration/deceleration time setting

The potentiometer ACC/DEC sets the acceleration and deceleration times of the motor. You can increase or decrease the acceleration/deceleration time by rotating ACC/DEC right and left. Setting range: 0.3-15s. The acceleration time is the time for the motor to reach the rated speed from the standstill. The deceleration time is the time for the motor to stop from the rated speed until the motor stops.

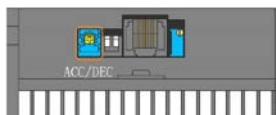

Motor pole number setting

In order to better match the DC brushless motor with different pole pairs, the number of motor pole pairs can be set via SW1.

ON=2P; OFF=4P

Note: When closed-loop control, set SW1 according to the number of motor pole pairs.



Open/closed loop control settings

Open/closed loop control is selected by SW2.

ON = closed-loop control; OFF = open-loop control.

Note: When closed-loop control, set SW1 according to the number of motor pole pairs.

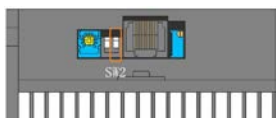

Peak output current setting

The P-sV potentiometer is used to set the peak output current. When the load suddenly increases, the output current is limited to the set value, which reduces the motor speed and protects the motor from damage.

Please set the peak current according to the graph scale

The error between setting the peak output current and the actual output current is about $\pm 10\%$. For safety reasons, please adjust the peak output current appropriately.

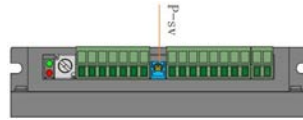
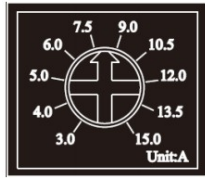

Note: When the load suddenly increases, the peak current setting time is 3s, more than 3s. If the load is still high, the driver will stop working. After 5s, the restart function will start.

Stall output current limit

When the motor is stalled, the output current will be limited to the set maximum output current, protecting the drive and motor from damage.

Stall torque retention function

When the motor is stalled, it has a simple torque retention function.

Note: Stall rotation holding torque is a short time behavior, please do not use it for brake blocking.

Restart function

When the motor stalls, etc., the driver will stop working. After 5s, the driver will start automatically. After restarting, if a fault occurs again, an alarm will be issued.

The protection function starts and stops working.

Start and stop

The factory settings for the EN and COM ports are to connect the EN and COM ports. When the power is turned on, the driver can drive the motor to run on its own.

Connecting or disconnecting the connecting wires of the EN and COM terminals controls the operation and stopping of the motor. When the connection between the EN side and COM side, the motor runs. Instead, the motor slowly stops.

By switching the COM and EN switches or using a PLC to control the ON/OFF, the motor can be switched between start and stop.

The factory settings for the BRK and COM ports are that the BRK and COM ports are not connected. When the power is turned on, the driver BLD-300B can drive the motor to run on its own.

The connection and disconnection of the BRK- and COM-connections can control the natural running and quick stop of the motor.

When the connection between BRK and COM is connected, the motor stops quickly.

The motor runs normally when the connection between BRK and COM is disconnected.

Note: The difference between EN and BRK and the use of choice:

- ① EN control is natural stop; BRK control is fast stop
- ② EN and BRK control start the same
- ③ When one of EN or BRK is selected to control the start-stop, the wiring of the other method should be kept at the factory.



Through the access switch between COM and BRK or using a PLC to control its on and off, the switching between motor start and quick stop can be realized.

The factory settings for the F/R and COM ports are that the F/R and COM ports are not connected.

When the power is turned on, the motor rotates forward.

Connect or disconnect the F/R and COM terminals to control the motor's forward and reverse rotation.

When the connection between F/R and COM is disconnected, the motor rotates forward.

When connecting the F/R end and the COM end, the motor reverses.

Direction control



Note: Observed from the direction of the motor shaft, the motor shaft rotates clockwise, and vice versa.



Speed control options and settings:

Use internal potentiometer RV speed

Rotate the built-in speed potentiometer RV clockwise. After a “click”, the motor starts to run. Continue to rotate clockwise, motor speed increases. Rotate the built-in speed-adjusting potentiometer RV counterclockwise to decrease the speed of the motor; continue counterclockwise rotation to the extreme position after “click”. At this time, the built-in speed potentiometer is closed and the motor stops running.

Note: When it is necessary to switch to the external SV input control speed mode, the built-in speed potentiometer RV must be closed. That is to say, the built-in potentiometer RV rotates counterclockwise to the extreme position after a click.

内置调速电位器 RV



Use external potentiometer to adjust speed

When using an external potentiometer for speed control, use a potentiometer with a resistance of 10KΩ. The middle lead end of the potentiometer is connected to the SV end, and the lead ends on both sides are respectively connected to REF+ and COM ends.

Note: ① At this time, the built-in speed control potentiometer RV needs to rotate counterclockwise to the limit position after a click.

② Be sure to pay attention to the connection order of the potentiometer leads.

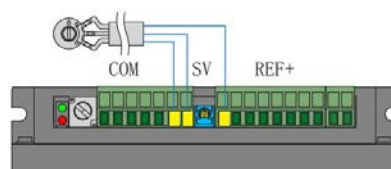

Speed regulation using external analog signal DC0-5V

Note: When it is necessary to switch to the external SV input control speed mode, the built-in speed potentiometer RV must be closed. That is, the built-in counter RV rotates counterclockwise to the extreme position of a click.

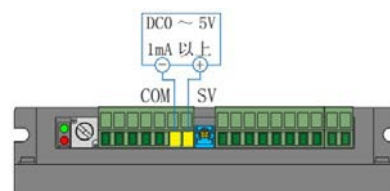

Analog signal voltage and motor speed relationship (open-loop no-load)

Analog signal voltage and motor speed relationship (closed-loop no-load)

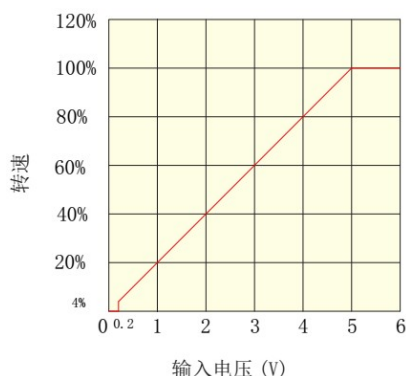

When the input voltage is approximately 0.2V, the motor speed is 4% of the maximum speed; when the input voltage is approximately 5V, the speed of the motor is the maximum. The maximum speed value depends on the motor size and supply voltage.

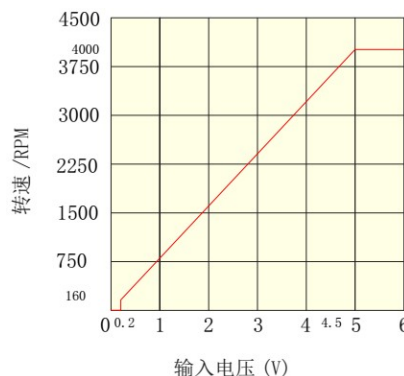

When the input voltage is about 0.2V, the motor speed is 160rpm; when the input voltage is about 5V, the speed of the motor is 4000rpm.

Use PWM speed

Note: When it is necessary to switch to the external SV input control speed mode, the built-in speed potentiometer RV must be closed. That is, the built-in counter RV rotates counterclockwise to the extreme position of a click.

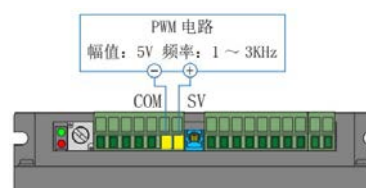

Relationship between duty cycle and motor speed
(open-loop no-load)

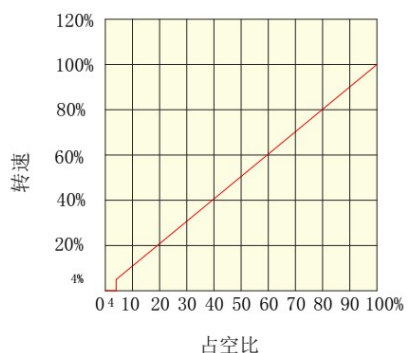

When the duty ratio is 4%, the motor speed is 4% of the maximum speed; when the duty ratio is 100%, the speed of the motor is the maximum value. The maximum speed value depends on the motor size and supply voltage.

The relationship between duty cycle and motor speed
(closed-loop no-load)

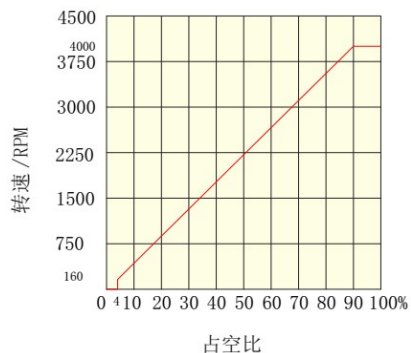

When the duty ratio is 4%, the motor speed is 160 rpm; when the duty ratio is 100%, the speed of the motor is the highest speed, 4000 rpm.

Status indication. Exception handling:

Status indication

When the motor has overcurrent, Hall input error, stall, over temperature, over voltage and other conditions, the driver will send an alarm signal. At this time, the fault alarm output (ALM) and the common (COM) will be turned on, so that the fault alarm output (ALM) will be at a low level. At the same time, the driver will stop working and the alarm light will flash.

red indicator	description	
red flash 2	over voltage alarm	
red flash 3	power tube over current alarm	
red flash 4	over current alarm	
red flash 5	under voltage alarm	
red flash 6	Hall alarm	
red flash 7	stall alarm	
red flash 8	two or more alarm	

Exception handling:

Red indicator	State description	
Red flashes 2 times	Overvoltage alarm	Please check the bus voltage
Red flashes 3 times	Power tube over-current alarm	Determine if the model is correct
Red flashes 4 times	Overcurrent alarm	Check the P-sv settings and check the motor parameters. Or increase the acceleration time
Red flashes 5 times	Undervoltage alarm	Check the power supply voltage and check if the power supply meets a condition that is greater than 1.5 times the motor power.
Red flashes 6 times	Hall Alarm	Please check if the motor wiring is firm
Red flashes 7 times	Locked alarm	Please determine if the motor is overloaded
Red flashes 8 times	Two or more alarms	Common conditions are Hall and locked-rotor alarms. When the motor cannot adjust the speed, please adjust P-sv to the maximum value